

HAKKO 850B

SMD REWORK STATION

SMD Rework Station

Instruction Manual



Thank you for purchasing the Hakko 850B SMD Rework Station.

The Hakko 850B is designed to solder and desolder surface mounted devices with hot air.

Please read this manual before operating the Hakko 850B. Keep this manual readily accessible for reference.



TABLE OF CONTENTS

PACKING LIST / SPECIFICATIONS	1
SAFETY INSTRUCTIONS	2
PART NAMES	3
PREPARATION: ASSEMBLY AND ELECTRICAL CONNECTION	4
OPERATION	5
MAINTENANCE / INSPECTION	7
TEMPERATURE DISTRIBUTION CHART	8
OPTIONAL NOZZLES	11
PARTS LIST / HANDPIECE	12
STATION	13
WIRING DIAGRAM	15

PACKING LIST

Check the contents of the Hakko 850B package and confirm that all the items listed below are included:

Hakko 850B station	1
Power cord	1
Handpiece holder	1
FP pick-up	1
FP pick-up wire	1
Instruction manual	1

* This product does not include a nozzle. A large selection of nozzles is available for the Hakko 850B. Select the nozzle or nozzles suitable for the work to be performed.

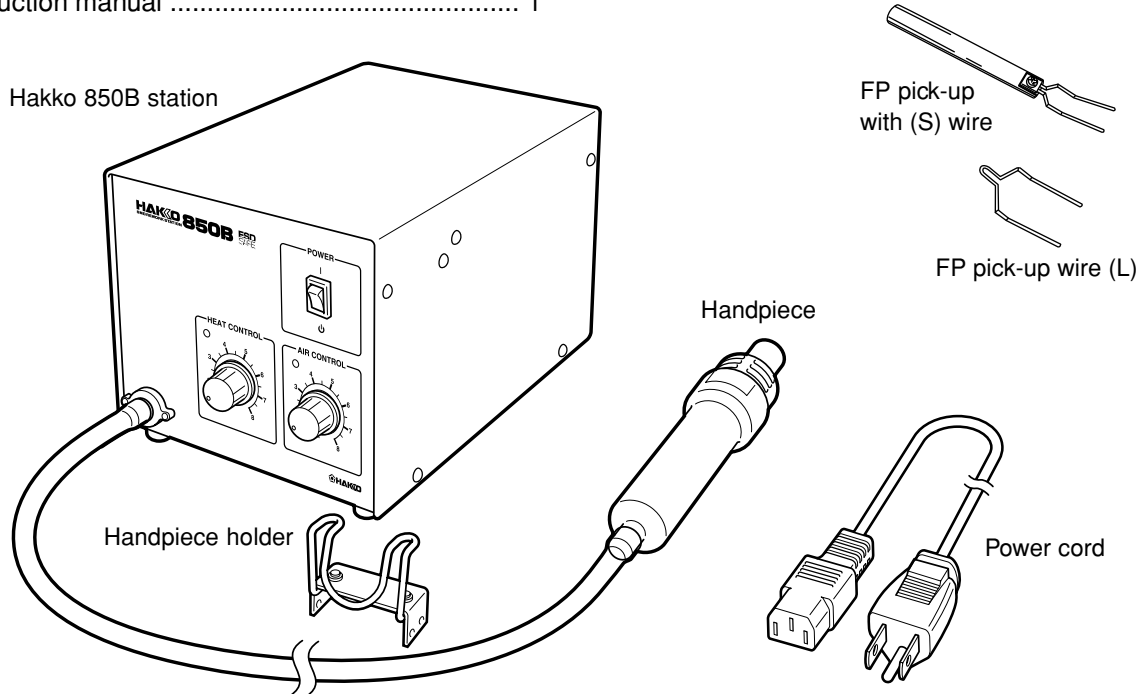

SPECIFICATIONS

Name	Hakko 850B
Power consumption	100V – 280W 110V – 270W 120V – 300W 220V – 300W 230V – 310W 240V – 310W

● Station

Power Consumption	30 W (Stand-by power consumption 100 – 120V 2W, 220 – 240V 4W)
Pump	Diaphragm pump
Capacity	23 ℓ/min (max)
Control temperature	100° – 420°C (212° – 788°F) (Use A1126B)
External dimensions	225(l) × 160(w) × 145(h) mm. 8.9(l) × 6.3(w) × 5.7(h) in.
Weight	4 kg. (8.82 lb.)

● Handpiece

Power consumption	100V – 250W 110V – 240W 120V – 270W 220V – 270W 230V – 280W 240V – 280W
Total length (w/o cord)	196(l) mm / 7.72(l) in.
Weight (w/o cord)	120 g / 0.26 lb.

* This product is ESD-protected.

* Specifications and design subject to change without notice.

SAFETY INSTRUCTIONS

WARNING

Warnings and cautions are placed at critical points in this manual to direct the operator's attention to significant items. They are defined as follows:

 **WARNING:** Failure to comply with a WARNING may result in serious injury or death.

 **CAUTION:** Failure to comply with a CAUTION may result in injury to the operator, or damage to the items involved. Two examples are given below.

● Be sure to comply with following WARNINGS and CAUTIONS for your safety.

WARNING

- Be sure not to operate the unit with any combination of temperature and air flow settings that makes the thermal protector trip (the heater lamp turns off during use). This could damage the unit.
- After use, do not disconnect the plug during the automatic cool-down process.

CAUTION

When the power is ON, the temperature of the hot air and the nozzle ranges from 100° to 450°C. (212° to 842°F.). To avoid injury to personnel or damage to items in the work area, observe the following:

- Do not direct the hot air toward personnel or touch the metal parts near the nozzle.
- Do not use the product near combustible gases or flammable materials.
- Advise those in the work area that the unit can reach very high temperatures and should be considered potentially dangerous.
- Turn the power OFF when no longer using the Hakko 850B or when leaving it unattended.
- Before replacing parts or storing the unit, allow the unit to cool and then turn the power OFF.

● To prevent accidents and failures, be sure to take the following precautions:

- Do not strike the handpiece against hard surfaces or otherwise subject it to physical shock. This will damage the quartz glass shield around the heating element, and could damage the heater as well.
- Be sure the unit is grounded. Always connect power to a grounded receptacle.
- Do not disassemble the pump.
- Do not modify the unit.
- Use only genuine Hakko replacement parts.
- Do not wet the unit or use the unit with wet hands.
- Remove power cord by holding the plug - not the wires.
- Make sure the work area is well ventilated.
- The Hakko 850B is not intended for use by children or infirm persons without supervision.
- Children should be supervised to ensure that they do not play with the Hakko 850B.

PART NAMES

Station

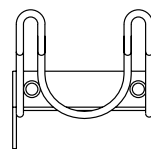
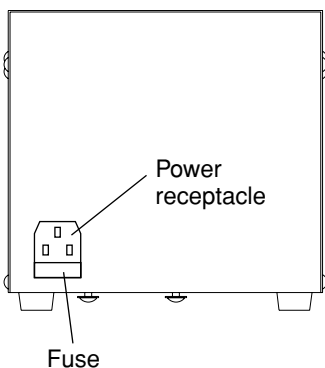
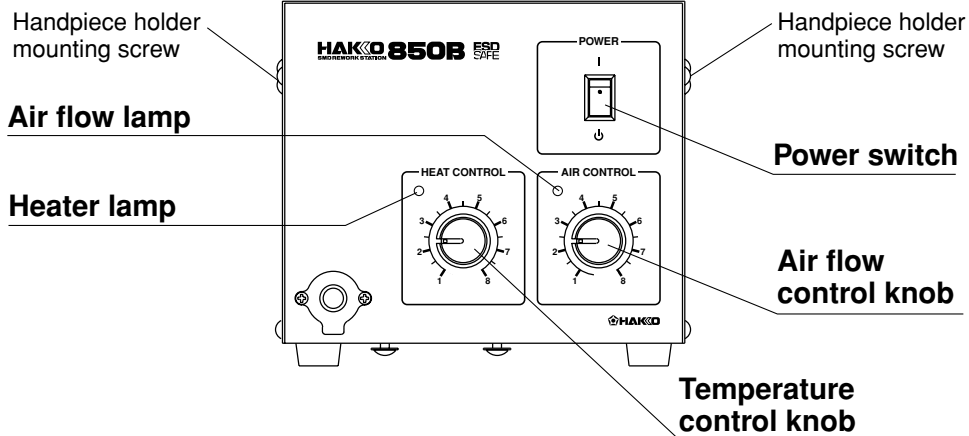

Handpiece holder

Handpiece

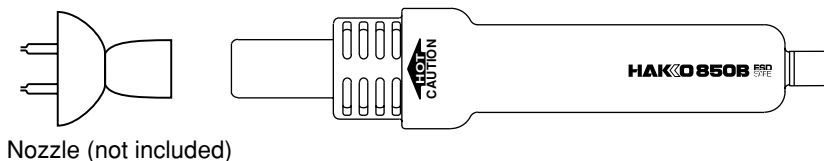

Accessories

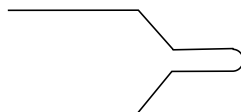
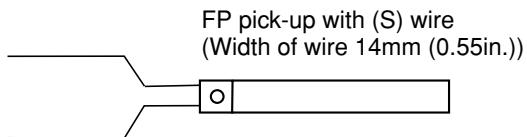

FP pick-up wire (L)
(Width of wire 30mm (1.18in.))

PREPARATION: ASSEMBLY AND ELECTRICAL CONNECTION

Preparation: Assembly and Electrical Connection

A. Station Assembly

● Attach the handpiece holder.

Remove the handpiece holder mounting screw from the side of the station. Attach the handpiece holder to the station. (Figure 1)
(The handpiece holder can be installed on either the left or right side.)

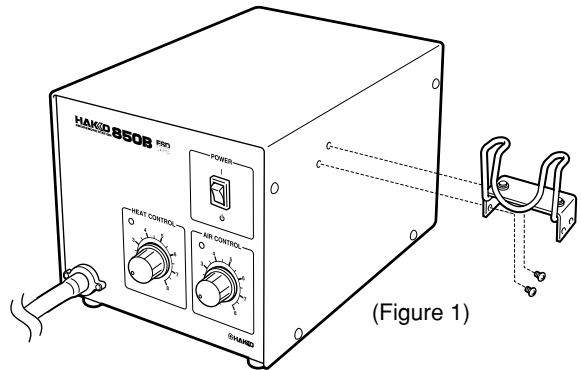

(Figure 1)

B. Handpiece Assembly

● Attach the nozzle.

Loosen the nozzle mounting screw. Attach the nozzle as shown in the drawing. (Figure 2)

Tighten the nozzle mounting screw.

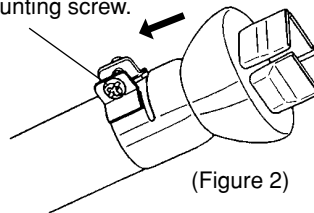

(Figure 2)

Inside screw

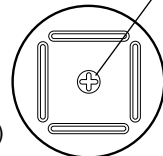

(Figure 3)

C. Electrical Connection and Power ON

1. Connect the power cord to the power receptacle on the back panel of the station. (Figure 4)
2. Place the handpiece on the holder. (Figure 5)
3. Plug the power cord into a grounded wall socket. After connection, the automatic blowing function will start sending air through the pipe, but the heating element remains cool.
4. Turn the power switch ON.

NOTE: The power switch may be turned on at any time while the automatic blowing function is operating. Once the power switch is turned on, the heating element will begin to warm up.

When installing an optional nozzle to the HAKKO 850B, do not remove this inside screw.

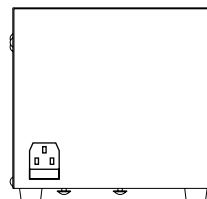

(Figure 4)

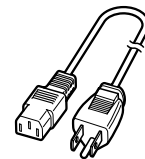

⚠ CAUTION

This product is ESD-protected. Be sure to use a grounded wall socket.

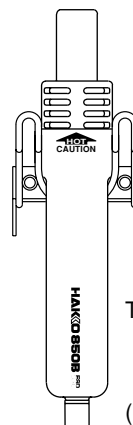

Top View

(Figure 5)

⚠ CAUTION

When not in use, place the handpiece on the holder.

OPERATION

● QFP Desoldering

1. Adjust the air flow and temperature control knobs.

Refer to the temperature distribution chart (page 8) to adjust the air flow and temperature control knobs. Wait for the temperature to stabilize for a short period of time.

⚠ WARNING

If the thermal protector is tripped (the heater lamp turns off during use), reduce the temperature setting or increase the air flow. Be sure not to operate the unit with temperature and air flow settings that makes the thermal protector trip. This could damage the unit.

2. Place the FP pick-up under the IC lead.

Slip the FP pick-up wire under the IC lead. (Refer to the photo shown.)

If the width of the IC does not match the size of the FP pick-up, adjust the width of the pick-up by squeezing the wire. In case of PLCC or small components such as chip resistors, desolder by using tweezers, etc.

3. Heating

Hold the handpiece so that the nozzle is located directly over, but not touching the IC, and allow the hot air to melt the solder. Be careful not to touch the leads of the IC with the nozzle.

4. Remove the IC.

Once the solder has melted, remove the IC by lifting the FP pick-up.

5. Remove any remaining solder.

After removing the IC, remove remaining solder with a soldering iron and wick or desoldering tool.

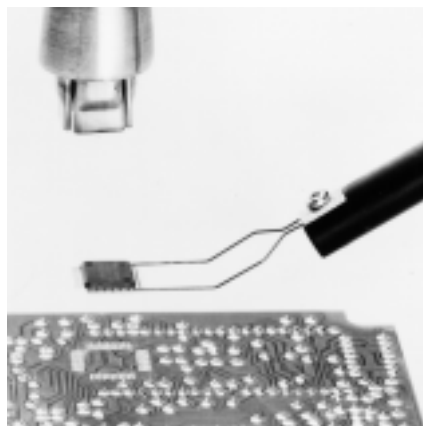
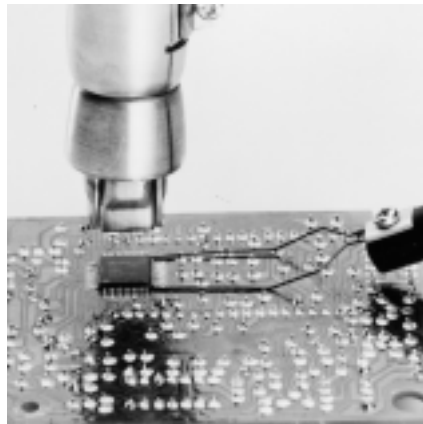
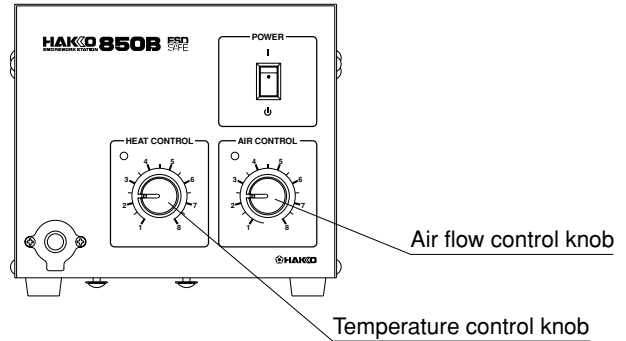

OPERATION

QFP Soldering

1. Apply the solder paste.

Apply the proper quality of solder paste and install the SMD on the PWB.

2. Preheat the SMD.

Refer to the photo to preheat SMD.

3. Soldering

Heat the lead frame evenly.

4. Cleaning

When soldering is completed, clean the residual flux from the board with an appropriate cleaner.

NOTE:

Soldering with hot air has many advantages, such as the inherent ability to pre-heat the component being replaced. As with any soldering process, however, there is always the possibility of forming solder balls, bridges between leads, and inadequate solder joints. Always inspect the finished solder joints for structural and electrical integrity.

Turn the power switch off.

After the power switch is turned off, an automatic blowing function begins sending cool air through the pipe in order to cool the handpiece. Do not disconnect the plug during this cooling process.

CAUTION

During the cooling process, the amount of air is controlled by the setting of the air flow adjustment knob. Hakko recommends setting the knob at 8 when cooling for greatest efficiency.

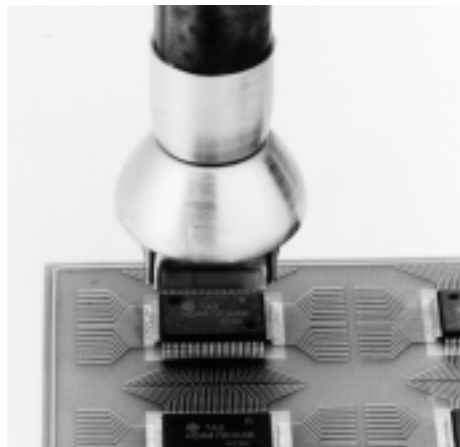
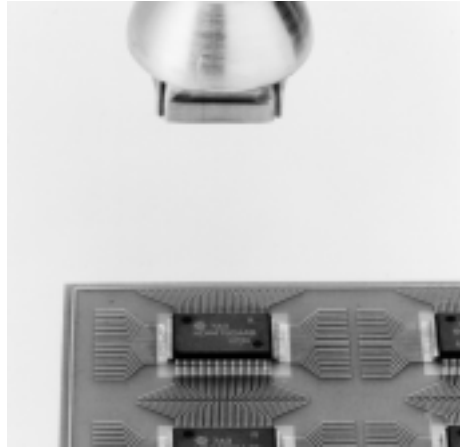

MAINTENANCE / INSPECTION

● Broken heating element

A. Open the handpiece

1. Remove the three screws holding the handpiece together. (Figure 1)
2. Move the tube away from the handpiece, as shown.
3. Open the handpiece. Disconnect the grounding wire sleeve (1) and pipe from the protruding portion of the handle. Remove the pipe.

⚠ CAUTION

Quartz glass and heat insulation are inside the pipe. Be careful not to drop or lose these items.

4. Disconnect the connector (2) and remove the heating element.

B. Measure the resistance value

Connect an ohmmeter across the connector terminals (a). The correct values are approximately:

26-40 Ω (100-120V), 70-100 Ω (220-240V).

If the resistance value is incorrect, replace the part.

(Refer to the instructions included with the replacement part.)

⚠ CAUTION

Handle the heating element with care. Never rub the heating element wire!

Insert the handle's projection into the hole in the pipe.

● Replacing the fuse

1. Unplug the power cord from the power receptacle.
2. Remove the fuse holder.
3. Replace the fuse.
5A (100-120V), 3.15A (220-240V)
4. Put the fuse holder back in place.

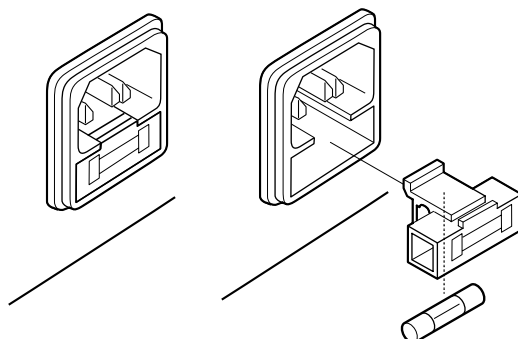
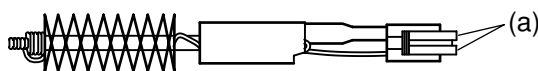
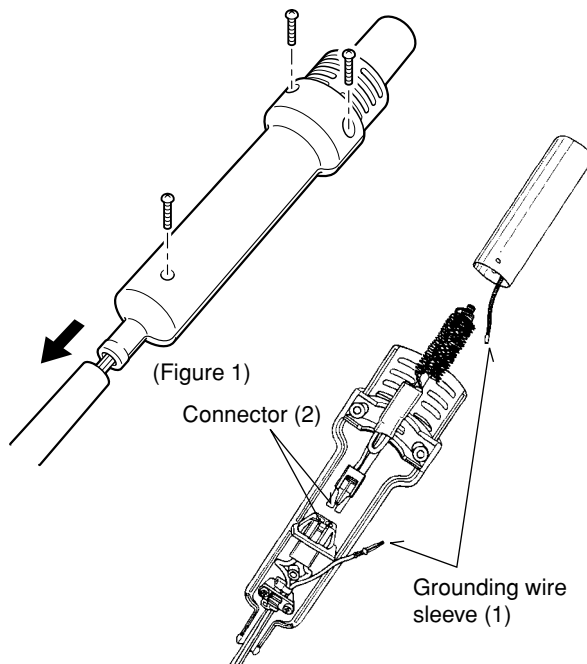

TEMPERATURE DISTRIBUTION CHART

CAUTION These charts are for reference. If the thermal protector trips, reduce the temperature setting or increase the air flow.

NOTE: Air-flow and temperature adjustment of the Hakko 850B

The temperature distribution chart relating air-flow and temperature settings for different nozzle types provided with the Hakko 850 are not to be used with the 850B. The 850B uses a different pump and control system and the flow-rates and temperature do not correspond.

Please refer to the temperature distribution chart in the 850B instruction manual before use.

Test criteria: Measured at a point 3mm (0.12 in.) from the nozzle by recorder.

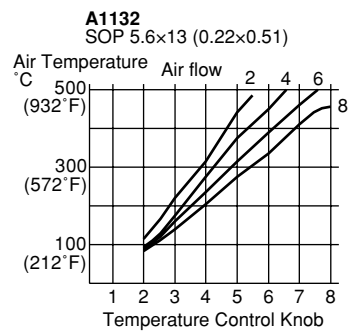
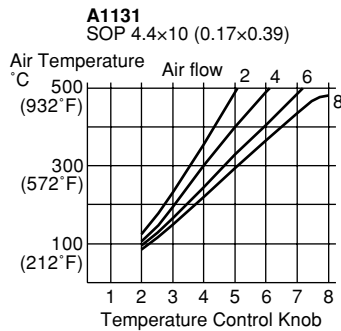
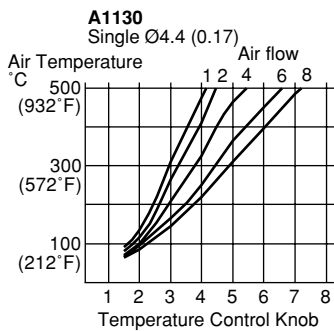
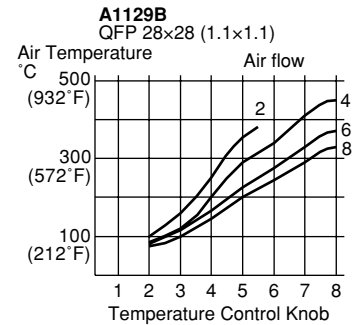
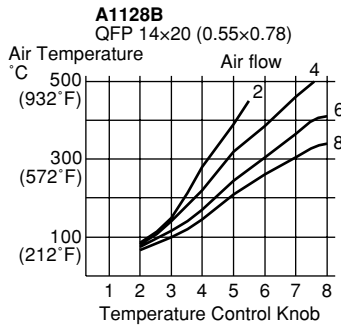
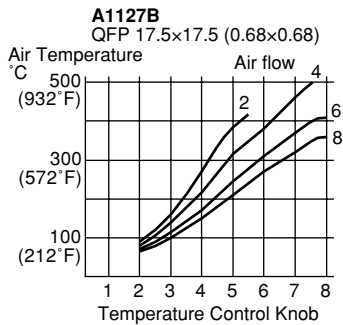
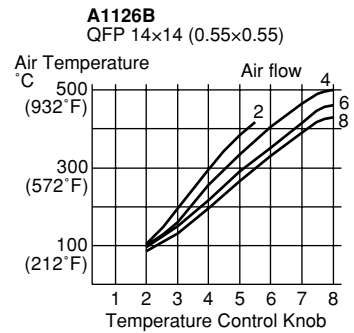
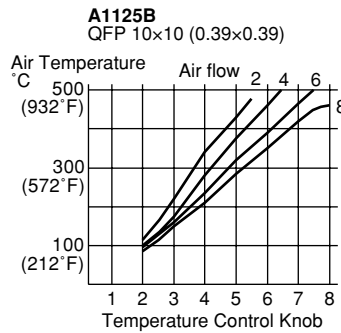
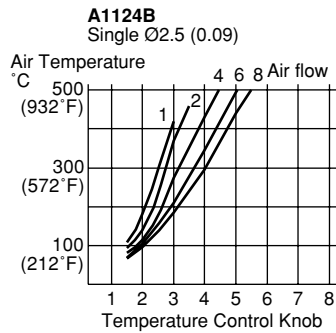

TEMPERATURE DISTRIBUTION CHART

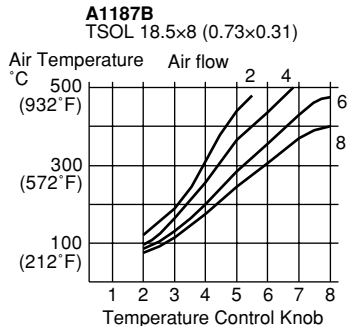
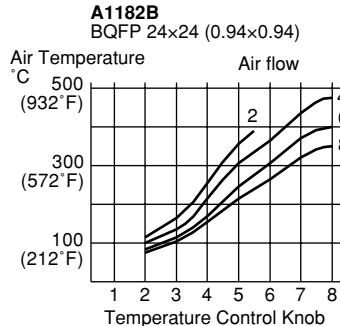
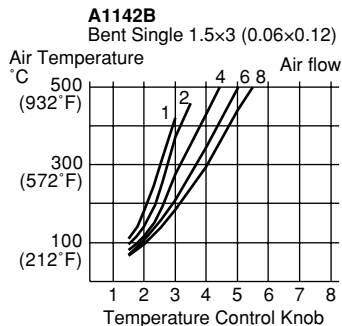
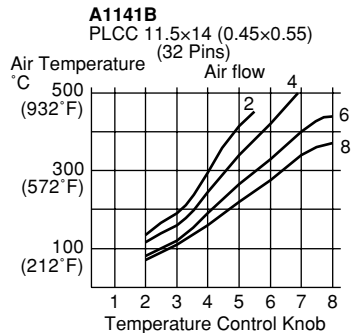
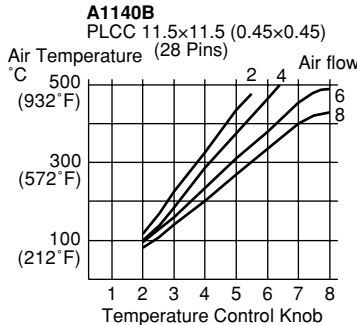
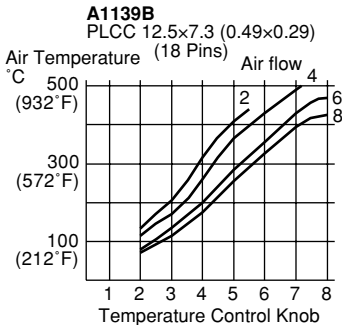
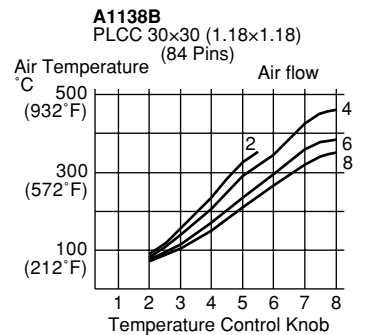
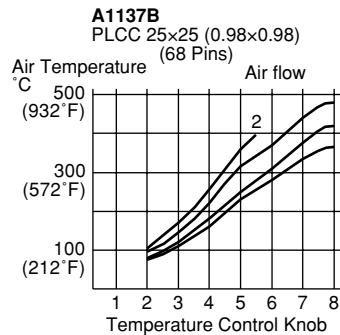
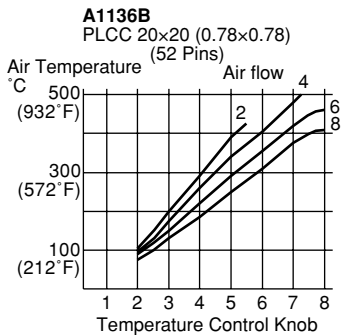
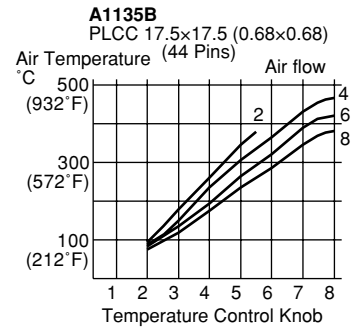
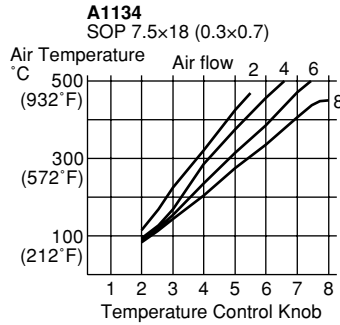
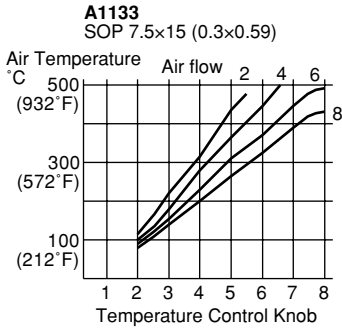

A1257B
SOP 11×21 (0.43×0.83)

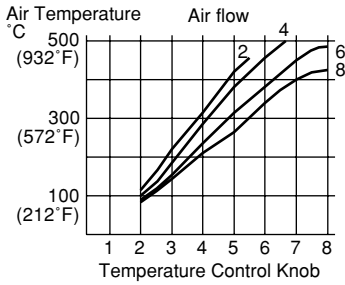

A1258B
SOP 7.6×12.7 (0.3×0.5)

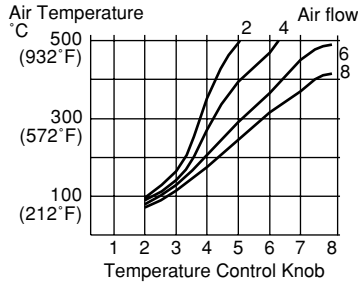

A1259B
SOP 13×28 (0.51×1.1)

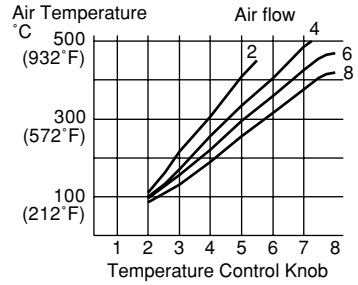

A1260B
SOP 8.6×18 (0.34×0.71)

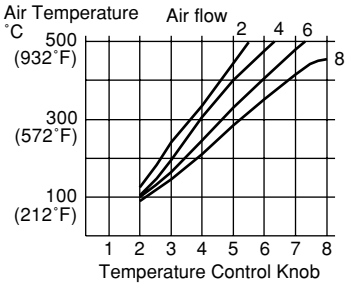

A1261B
QFP 20×20 (0.78×0.78)

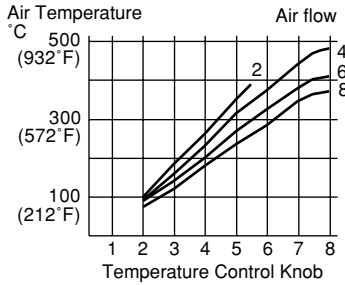

A1262B
QFP 12×12 (0.47×0.47)

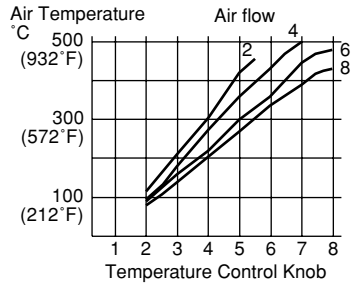

A1263B
QFP 28×40 (1.1×1.57)

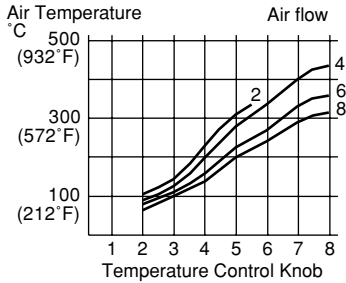

A1264B
QFP 40×40 (1.57×1.57)

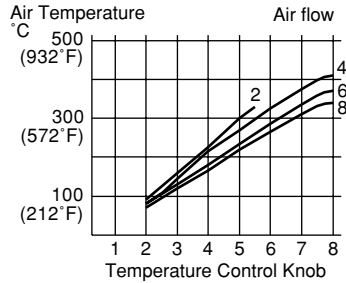

A1265B
QFP 32×32 (1.26×1.26)

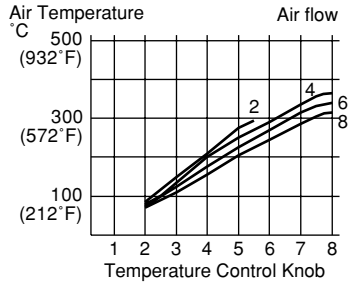

A1325
Dual Single Ø1.5×5-10
(0.06×0.2-0.39)

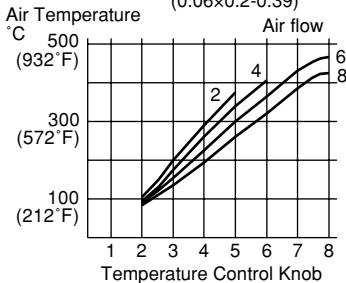

OPTIONAL NOZZLES

NOTE:

The size in Name/
Specification
indicates the size
of IC package.

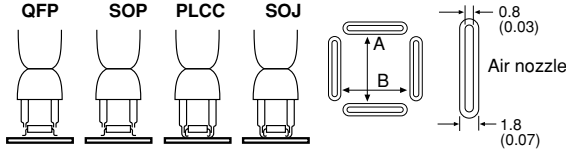

mm (inch)

<p>A1124B Single $\varnothing 2.5$ (0.09)</p> <p>$\varnothing 2.5$ (I.D.) (0.09)</p>	<p>A1125B QFP 10x10 (0.39x0.39)</p> <p>A:10.2 (0.4) B:10.2 (0.4)</p>	<p>A1126B QFP 14x14 (0.55x0.55)</p> <p>A:15.2 (0.6) B:15.2 (0.6)</p>	<p>A1127B QFP 17.5x17.5 (0.68x0.68)</p> <p>A:19.2 (0.76) B:19.2 (0.76)</p>	<p>A1128B QFP 14x20 (0.55x0.78)</p> <p>A:15.2 (0.6) B:21.2 (0.83)</p>
<p>A1129B QFP 28x28 (1.1x1.1)</p> <p>A:29.7 (1.17) B:29.7 (1.17)</p>	<p>A1130 Single $\varnothing 4.4$ (0.17)</p> <p>$\varnothing 4.4$ (I.D.) (0.17)</p>	<p>A1131 SOP 4.4x10 (0.17x0.39)</p> <p>4.8 (0.19) 10 (0.39)</p>	<p>A1132 SOP 5.6x13 (0.22x0.51)</p> <p>5.7 (0.22) 15 (0.59)</p>	<p>A1133 SOP 7.5x15 (0.3x0.59)</p> <p>7.2 (0.28) 16 (0.63)</p>
<p>A1134 SOP 7.5x18 (0.3x0.7)</p> <p>7.2 (0.28) 19 (0.75)</p>	<p>A1135B PLCC 17.5x17.5 (0.68x0.68) (44 Pins)</p> <p>A:18.5 (0.73) B:18.5 (0.73)</p>	<p>A1136B PLCC 20x20 (0.78x0.78) (52 Pins)</p> <p>A:21 (0.83) B:21 (0.83)</p>	<p>A1137B PLCC 25x25 (0.98x0.98) (68 Pins)</p> <p>A:26 (1.02) B:26 (1.02)</p>	<p>A1138B PLCC 30x30 (1.18x1.18) (84 Pins)</p> <p>A:31 (1.22) B:31 (1.22)</p>
<p>A1139B PLCC 12.5x7.3 (0.49x0.29) (18 Pins)</p> <p>A:9 (0.35) B:14 (0.55)</p>	<p>A1140B PLCC 11.5x11.5 (0.45x0.45) (28 Pins)</p> <p>A:13 (0.51) B:13 (0.51)</p>	<p>A1141B PLCC 11.5x14 (0.45x0.55) (32 Pins)</p> <p>A:15 (0.59) B:13 (0.51)</p>	<p>A1142B Bent Single 1.5x3 (0.06x0.12)</p> <p>1.5 (0.06) (I.D.) 3 (0.12) (I.D.) 45°</p>	<p>A1182B BQFP 24x24 (0.94x0.94)</p> <p>A:24.2 (0.95) B:24.2 (0.95)</p>
<p>A1187B TSOL 18.5x8 (0.73x0.31)</p> <p>10 (0.39) 18.5 (0.73)</p>	<p>A1257B SOP 11x21 (0.43x0.83)</p> <p>21 (0.83) 11.7 (0.46)</p>	<p>A1258B SOP 7.6x12.7 (0.3x0.5)</p> <p>11.7 (0.46) 8.2 (0.32)</p>	<p>A1259B SOP 13x28 (0.51x1.1)</p> <p>29 (1.14) 13.5 (0.53)</p>	<p>A1260B SOP 8.6x18 (0.34x0.71)</p> <p>19 (0.75) 8.7 (0.34)</p>
<p>A1261B QFP 20x20 (0.78x0.78)</p> <p>A:20.2 (0.8) B:20.2 (0.8)</p>	<p>A1262B QFP 12x12 (0.47x0.47)</p> <p>A:12.2 (0.48) B:12.2 (0.48)</p>	<p>A1263B QFP 28x40 (1.1x1.57)</p> <p>A:27.7 (1.09) B:39.7 (1.56)</p>	<p>A1264B QFP 40x40 (1.57x1.57)</p> <p>A:40.2 (1.58) B:40.2 (1.58)</p>	<p>A1265B QFP 32x32 (1.26x1.26)</p> <p>A:32.2 (1.27) B:32.2 (1.27)</p>
<p>A1325 Dual Single $\varnothing 1.5 \times 5-10$ (0.06x0.2-0.39) Adjustable Pitch</p> <p>5 (0.2) 10 (0.39)</p> <p>The pitch between the two nozzles is adjustable.</p>	<p>10 (0.39) 5 (0.2)</p> <p>$\varnothing 1.5$ (I.D.) (0.06)</p> <p>Screw</p>			

PARTS LIST / HANDPIECE

NOTE:

Spare or repair parts do not include mounting screws, if they are not listed on the description. Screws must be ordered separately.

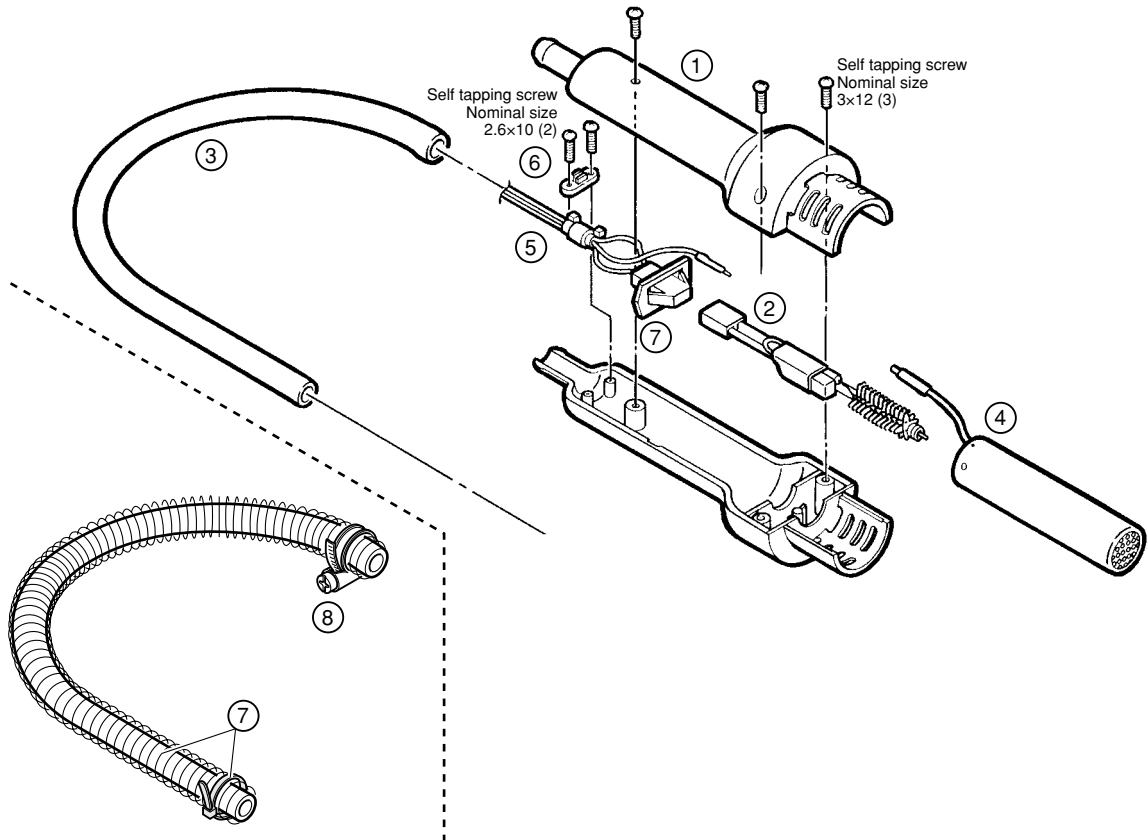

Item No.	Part No.	Part Name	Description
1	B2544	Handle	With screws
2	A1143	Heating element	100V
	A1144	Heating element	110V
	A1145	Heating element	120V
	A1146	Heating element	220-240V
3	B1188	Silicone hose	
4	B1441	Pipe assembly	
5	B2556	Cord assembly	
6	B1354	Cord stopper	With screws
7	B2634	Protective spring	(120V only) With nylon strap
8	B2635	Clamp	(120V only)

PARTS LIST / STATION

NOTE:

Spare or repair parts do not include mounting screws, if they are not listed on the description. Screws must be ordered separately.

Item No.	Part No.	Part Name	Description
1	B2539	Cover	
2	B2477	Handpiece holder assembly	
3	B2472	Sound-proof tank	
4	B2471	Air pump	100V, with high nut, nylon tape, double-side tape
	B2480	Air pump	110-120V, with high nut, nylon band, double-side tape
	B2481	Air pump	220-240V, with high nut, nylon band, double-side tape
5	B2473	Silicone tube	8 ϕ 5 \times 130 l (mm.) 0.3 ϕ 0.2 ϕ 5.11 (in.)
6	B2468	Fuse	125V-5A
	B1258	Fuse	250V-3.15A
7	B2384	Power receptacle	
8	B2540	Chassis	
9	B2463	Radiation sheet	
10	B2542	P.W.B.	100V, with potentiometer, triac
	B2545	P.W.B.	110-120V, with potentiometer, triac
	B2546	P.W.B.	220-230V, with potentiometer, triac
	B2547	P.W.B.	240V, with potentiometer, triac
11	B2541	Switch	
12	B2537	Air nozzle	With cord stopper
13	B1028	Knob	With screw
14	B1204	Rubber foot	Set of 4
15	n	Exhaust nozzle	If you need exhaust nozzle, contact your Hako representative.
16	B2543	Tube connector	With silicone tube
17	B2419	Power cord, 3 core & American plug	
	B2421	Power cord, 3 core, no plug	
	B2422	Power cord, 3 core, BS plug	India
	B2423	Power cord, 3 core European plug	Korea
	B2424	Power cord, 3 core European plug	Eur.
	B2425	Power cord, 3 core, BS plug	U.K.
	B2426	Power cord, 3 core, Australian plug	
	B2436	Power cord, 3 core, Chinese plug	

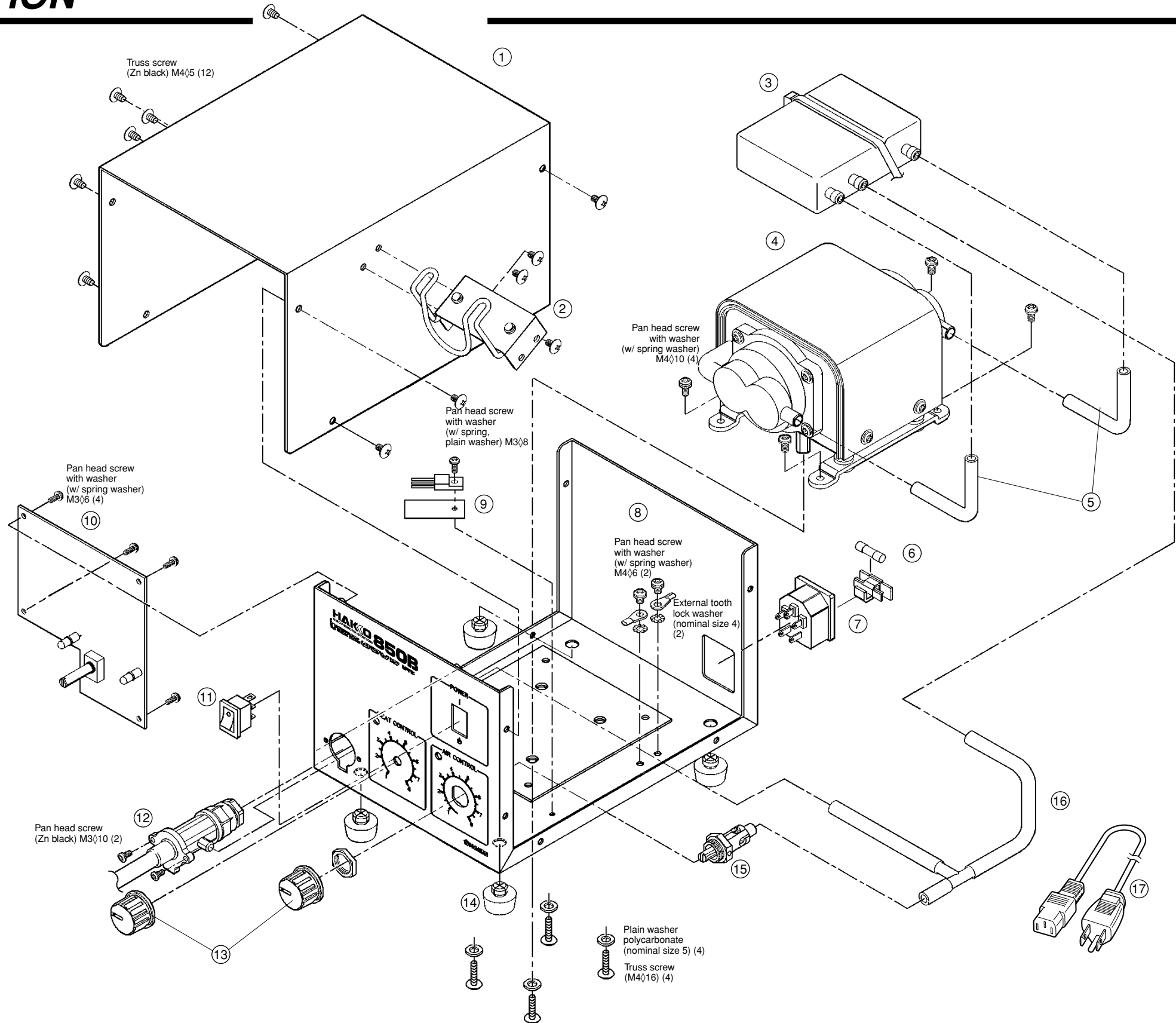

WIRING DIAGRAM

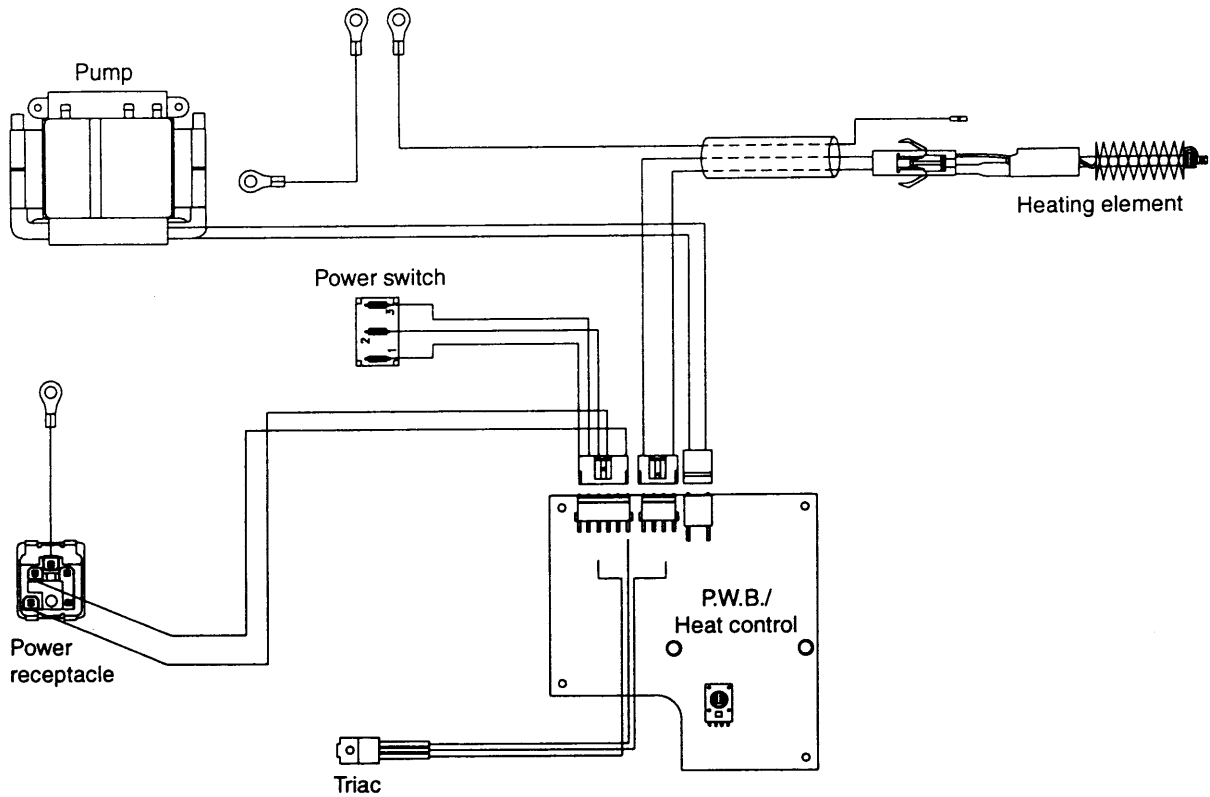

HAKKO CORPORATION

OVERSEAS AFFILIATES

U.S.A.: AMERICAN HAKKO PRODUCTS, INC.
28920 N. AVENUE WILLIAMS VALENCIA, CA 91355, U.S.A.
TEL: (661) 294-0090 FAX: (661) 294-0096
Toll Free (800)88-HAKKO
<http://www.hakkousa.com>

HONG KONG: HAKKO DEVELOPMENT CO., LTD.
ROOM 1504, EASTERN HARBOUR CENTRE
28 HOI CHAK STREET, QUARRY BAY, HONG KONG.
TEL: 2811-5588 FAX: 2590-0217
<http://www.hakko.com.hk>
E-mail: info@hakko.com.hk

CHINA: HAKKO DEVELOPMENT CO., LTD.
ROOM 1112-1115, 11 FLOOR, INTERNATIONAL BANK
TOWER 191 DONGFENG ROAD WEST, GUANGZHOU
510180, CHINA
TEL: (020)8135-0112, 8135-0113 FAX: (020)8135-0181
<http://www.hakko.com.hk>
E-mail: hakko@public.guangzhou.gd.cn

HEAD OFFICE

4-5, SHIOKUSA 2-CHOME, NANWA-KU, OSAKA, 556-0024 JAPAN
TEL: +81-6-6561-3225 FAX: +81-6-6561-8466
<http://www.hakko.com> E-mail: sales@hakko.com

TAIWAN: HAKKO DEVELOPMENT CO., LTD.
SF. NO. 111-1, HSIUNG TE RD., SANCHUNG, TAIPEI
HSIEN, TAIWAN, R.O.C.
TEL: (02)8512-4588 FAX: (02)8512-4258
E-mail: hakko110@ms31.hinet.net

SINGAPORE: HAKKO PRODUCTS PTE., LTD.
1, GENTING LINK #02-04, PERFECT INDUSTRIAL
BUILDING, SINGAPORE 349518
TEL: 748-2277 FAX: 744-0033
<http://www.hakko.com.sg>
E-mail: sales@hakko.com.sg

MALAYSIA: HAKKO PRODUCTS SDN BHD
MALAYSIA HEAD OFFICE
NO.22, JALAN PEMBERITA U1/49, SEKSYEN U1,
TEMASYA INDUSTRIAL PARK 40150 GLENMARIE
SHAH ALAM, SELANGOR DARUL EHSAN WEST MALAYSIA
TEL: (03)5569-5223 FAX: (03)5569-5221
E-mail: hakkokl@tm.net.my

PENANG BRANCH

19, LORONG IKS JURU 3, TAMAN PERINDUSTRIAN RINGAN JURU,
14100 SEBERANG PERAI TENGAH, PENANG, MALAYSIA
TEL: (04)507-0888 FAX: (04)507-0999 E-mail: hakkopg@tm.net.my

JOHOR BAHRU BRANCH
45A, JALAN SRI BAHAGIA 5, TAMAN SRI BAHAGIA,
81200 JALAN TAMPOI, JOHOR BAHRU, MALAYSIA.
TEL: (07)236-7766 FAX: (07)237-4655
E-mail: hakkojb@tm.net.my

PHILIPPINES: HAKKO PHILS TRADING CO., INC.
GROUND FLOOR HAKKO BUILDING 1ST STREET CORNER
3RD STREET UNITED PARANAQUE 5. SUBDIVISION SAN DIONISIO
PARANAQUE CITY PHILIPPINES
TEL: (02)825-5404, 826-6165 FAX: (02)829-3769
E-mail: hakkophil@pacific.net.ph

INDONESIA: P.T. HAKKO PRODUCTSTAMA INDONESIA

BATAM BRANCH
COMP BUMI INDAH BLOK IV NO 40 NAGOYA BATAM, INDONESIA
TEL: (778)457-459 FAX: (778)452-772 E-mail: hakkobtm@indosat.net.id

JAKARTA BRANCH
KEBON JERUK PLAZA BLOK D NO 6 JALAN RAYA PERJUANGAN
JAKARTA BARAT, 11530, INDONESIA
TEL: (21)532-4083 FAX: (21)532-4082 E-mail: hakkojkt@cbn.net.id