

Maintenance & Checking

1. PARTS LIST

NOTE:

Spare or repair parts do not include mounting screws, if they are not listed on the specifications. Screw must be ordered separately.

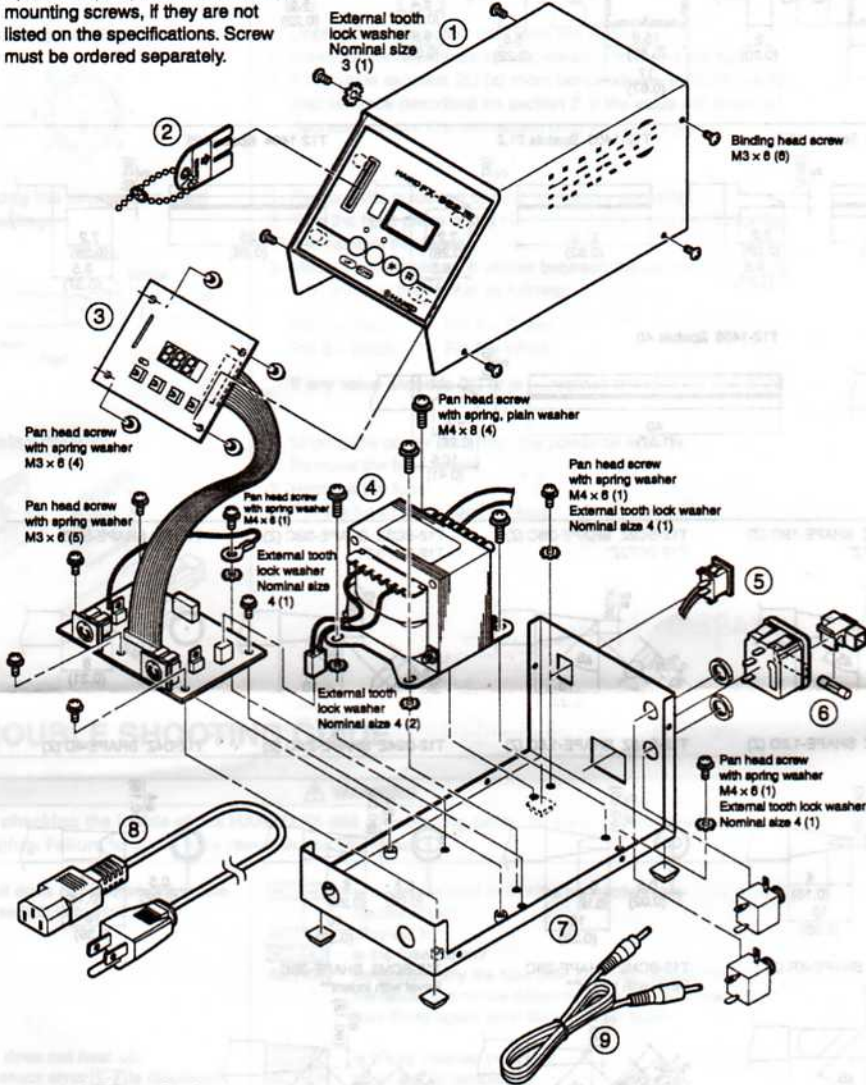

● HAKKO FX-952 Station

Item No.	Part No.	Part Name	Specifications
①	B2894	Cover	With membrane sheet
②	B2388	Control card	
③	B3297	P.W.B.	For temperature control and power supply
④	B2855	Transformer	100V
	B2856	Transformer	110V
	B2857	Transformer	220V
	B2858	Transformer	230V
	B2863	Transformer	240V
⑤	B2852	Switch	
⑥	B2761	Fuse, 250V - 3A	100 - 120V
	B2864	Fuse, 250V - 1.6A	220 - 240V

Item No.	Part No.	Part Name	Specifications
⑦	B3298	Chassis	With rubber foot
⑧	B2419	Power cord, 3 wired cord & American plug	
	B2421	Power cord, 3 wired cord & no plug	
	B2422	Power cord, 3 wired cord & BS plug	
	B2424	Power cord, 3 wired cord & European plug	220V KTL 230V CE
	B2425	Power cord, 3 wired cord & BS plug	230V CE
	B2426	Power cord, 3 wired cord & Australian plug	230 - 240V
	B2436	Power cord, 3 wired cord & Chinese plug	
	⑨	B3253	Connecting cable

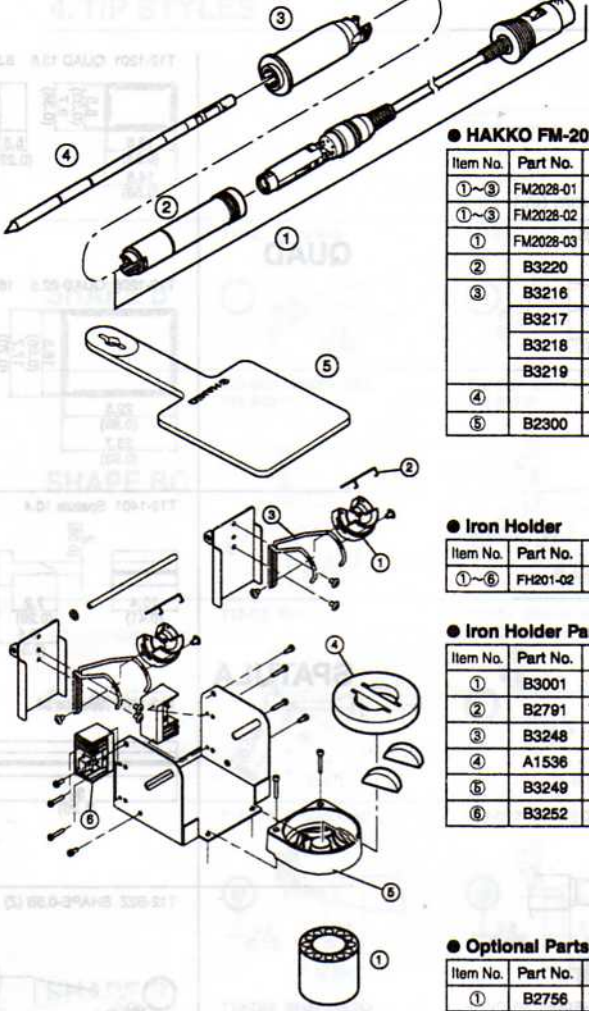

● HAKKO FM-2028

Item No.	Part No.	Part Name	Specifications
①~③	FM2028-01	HAKKO FM-2028	③ is yellow
①~③	FM2028-02	HAKKO FM-2028	③ is blue
①	FM2028-03	Connector assembly	
②	B3220	Connector cover	
③	B3216	Sleeve assembly	Yellow
	B3217	Sleeve assembly	Orange
	B3218	Sleeve assembly	Blue
	B3219	Sleeve assembly	Green
④		Tip	See back page.
⑤	B2300	Heat resistant pad	

● Iron Holder

Item No.	Part No.	Part Name	Specifications
①~⑥	FH201-02	Iron holder	With cleaning sponge

● Iron Holder Parts

Item No.	Part No.	Part Name	Specifications
①	B3001	Iron receptacle	Screws attached
②	B2791	Tip fixing spring	
③	B3248	Holder for iron receptacle	
④	A1536	Cleaning sponge	
⑤	B3249	Cleaner base	Rubber feet attached
⑥	B3252	Switch case assembly	

● Optional Parts

Item No.	Part No.	Part Name	Specifications
①	B2756	Tip tray	

2. MAINTENANCE/CHECKING PROCEDURE

Performing proper and periodical maintenance extends the products life and contributes to use it always in a good condition. Efficient soldering depends upon the temperature, the quality and quantity of the solder and flux. Apply the following service procedure as dictated by the conditions of the usage.

⚠ WARNING

Since the soldering iron can reach a very high temperature, please work carefully. Except the case especially indicated, always turn the power switch OFF and disconnect the power plug before performing any maintenance procedure.

● Tip maintenance

1. Tip temperature

High temperatures shorten tip life and may cause thermal shock to components. Always use the lowest possible temperature when soldering. The excellent thermal recovery characteristics of the HAKKO FX-952 ensure effective soldering at low temperatures.

2. Cleaning

Always clean the soldering tip before use, to remove any residual solder or flux adhering to it. Use a clean and moist cleaning sponge (Parts No. A1536 provided with the HAKKO FX-952) or the HAKKO 599B tip cleaner. Contaminants on the tip have many deleterious effects, including reduced heat conductivity, which contribute to poor soldering performance.

3. After use

Always clean the tip and coat it with fresh solder after use. This guards against oxidation.

4. When the unit is not being used and the auto power shutoff is not active.

Never allow the unit to idle at a high temperature for extended periods. This will allow the tip to become oxidized. Turn the power switch OFF. If it is to be out of service for several hours, it is advisable to pull the power plug as well.

5. Inspecting and cleaning the tip

This procedure, if followed daily, will materially add to tip life.

1. Set the temperature to 250°C. (482°F.)
2. When the temperature stabilizes, clean the tip (see 2, above) and check the condition of the tip. If the tip is badly worn or deformed, replace it.
3. If the solder plated part of the tip is covered with black oxide, apply fresh solder, containing flux, and clean the tip again. Repeat until all the oxide is removed, then coat the tip with fresh solder.
4. Turn the power OFF and remove the tip, using the heat resistant pad. Set the tip aside to cool.
5. Remaining oxides, such as the yellow discoloration on the tip shaft, can be removed with isopropyl alcohol.

⚠ CAUTION
NEVER file the tip to remove oxides!

● Checking Procedure

⚠ WARNING

Unless otherwise directed, carry out these procedures with the power switch OFF and the power UNPLUGGED.

● Check for a broken heater or sensor

1. Check for a broken heater or sensor

Measure the resistance across this position.



Verify the electrical integrity of the heater and sensor. Measure the resistance of the heater and sensor while at room temperature (15 to 25°C.; 59 to 77°F.). It should be $8\Omega \pm 10\%$. If the resistance exceeds these limits, replace the tip.

● Check the grounding line



1. Unplug the connection cord from the station.
2. Measure the resistance value between Pin 2 and the tip.
3. If the value exceeds 2Ω (at room temperature), perform the tip maintenance described on section 2. If the value still does not decrease, check the connection cord for breakage.

● Checking the connection cord for breakage

1. Remove the soldering tip and the sleeve assembly.
2. Turn the front piece of the HAKKO FM-2028 counterclockwise and remove the cover.
3. Measure the resistance values between the connector and the lead wires at the socket as follows:

Pin 1 – Red Pin 2 – Green
Pin 3 – Black Pin 5 – White

If any value exceeds 0Ω or is ∞ , replace the HAKKO FM-2028.

● Replacing the fuse

1. Unplug the power cord from the power receptacle.
2. Remove the fuse holder.
3. Replace the fuse.
4. Put the fuse holder back in place.

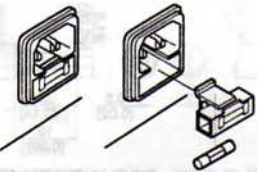
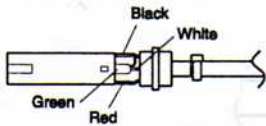

3. TROUBLE SHOOTING GUIDE

⚠ WARNING

Before checking the inside of the HAKKO FX-952 or replacing parts, be sure to disconnect the power plug. Failure to do so may result in electric shock.

● The unit does not operate when the power switch is turned on.

- CHECK** : Is the power cord and/or the connection plug disconnected?
ACTION : Connect it.
CHECK : Is the fuse blown?
ACTION : Investigate why the fuse blew and then replace the fuse. If the cause can not be determined, replace the fuse. If the fuse blows again, send the unit in for repair.

● The tip does not heat up. • The sensor error [S-E] is displayed.

- CHECK** : Is the tip inserted properly?
ACTION : Insert the tip completely.
CHECK : Is the connection cord and/or the heater/sensor broken?
ACTION : See the appropriate section of this manual regarding how to check the connection cord and/or the heater/sensor for breakage.

● Solder does not wet the tip.

- CHECK** : Is the tip temperature too high?
ACTION : Set the appropriate temperature.
CHECK : Is the tip contaminated with oxide?
ACTION : Remove the oxide (see "Tip maintenance" on section 2).

● The tip temperature is too high.

- CHECK** : Is the connection cord broken?
ACTION : See "Checking the connection cord for breakage" on section 2.
CHECK : Is the entered offset value correct?
ACTION : Enter the correct value.

● The tip temperature is too low.

- CHECK** : Is the tip contaminated with oxide?
ACTION : Remove the oxide (see "Tip maintenance" on section 2).
CHECK : Is the entered offset value correct?
ACTION : Enter the correct value.

● The soldering iron error is displayed.

- CHECK** : Is incorrect soldering iron connected?
ACTION : Connect the HAKKO FM-2028 soldering iron.

● The low-temperature alarm tolerance error occurs frequently.

- CHECK** : Is the tip contaminated with oxide?
ACTION : Remove the oxide (see "Tip maintenance" on section 2).
CHECK : Is the entered offset value correct?
ACTION : Enter the correct value.

● Heater terminal short circuit error [C-E] is displayed.

- CHECK** : Is the tip for HAKKO FM-2028 soldering iron?
ACTION : Connect the HAKKO FM-2028 soldering iron.